

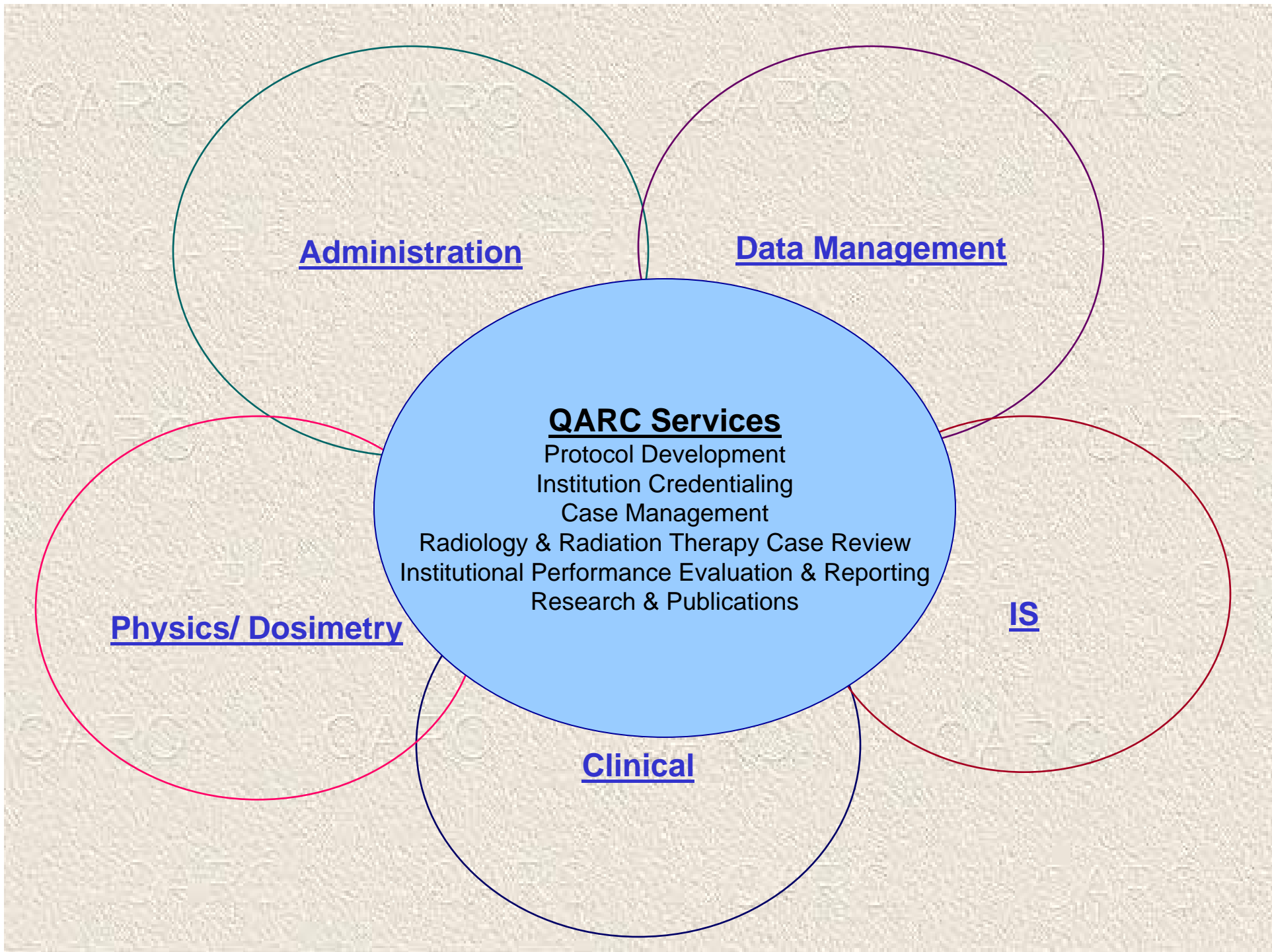

- Funded by the National Cancer Institute since 1980
- Provides Radiation Therapy Quality Assurance and Diagnostic Imaging Data Management for Radiation Oncology and Diagnostic Imaging Programs for six NCI supported Cooperative Groups
- Affiliated with the University of Massachusetts Medical School 1996. Located in Providence, Rhode Island
- Dr. T. J. FitzGerald, QARC Director

# Cooperative Groups

- American College of Surgeons - ACOSOG
  - Cancer and Leukemia Group B – CALGB
  - Children's Oncology Group – COG
  - Eastern Cooperative Oncology Group - ECOG
  - Pediatric Brain Tumor Consortium – PBTC
  - Southwest Oncology Group – SWOG
- 
- Industry Trials



# QARC – Patient Enrollments

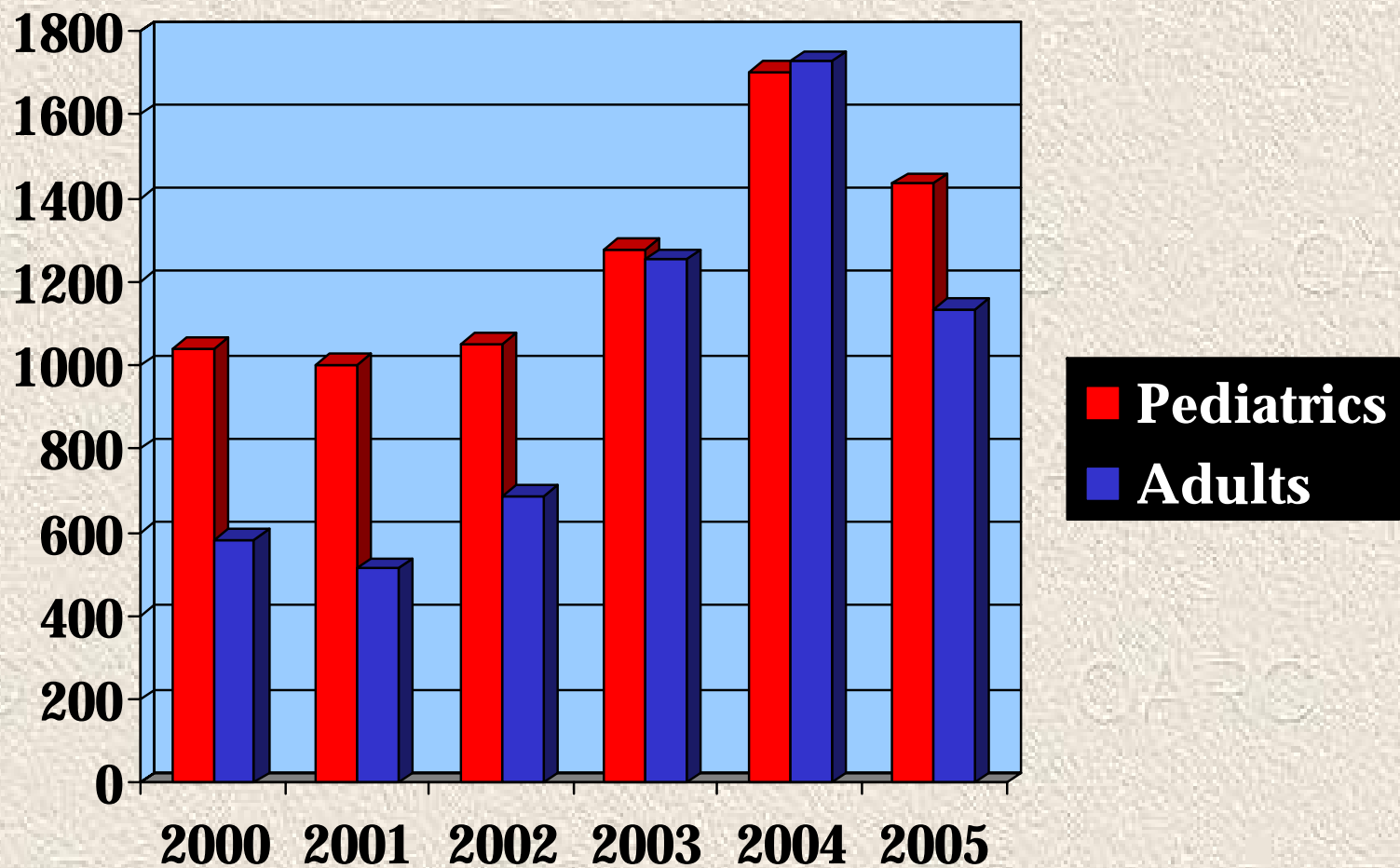

# QARC – Protocols

| Group    | Active/Open | Active/Total | In Development |
|----------|-------------|--------------|----------------|
| ACOSOG   | 3           | 6            | 2              |
| CALGB    | 6           | 13           | 1              |
| COG      | 27          | 69           | 32             |
| ECOG     | 6           | 22           | 6              |
| PBTC     | 1           | 4            | 1              |
| SWOG     | 12          | 15           | 4              |
| Industry | 3           | 4            | 2              |

Total Active: 133

# Modern Protocol

---

---

- **Multiple endpoints with correlative studies**
- **Advanced Technologies**
- **New requirements for real time central reviews including metabolic imaging reviews**
- **In COG there are 45 studies with diagnostic imaging central reviews that are active or about to open**
- **Need for QARC to facilitate this role**
- **A partnership with OSU image core lab for CALGB**
- **Develop partnership for other adult studies**

# AHOD0031: Multiple Roles of QARC

## QARC Confirmation of CR

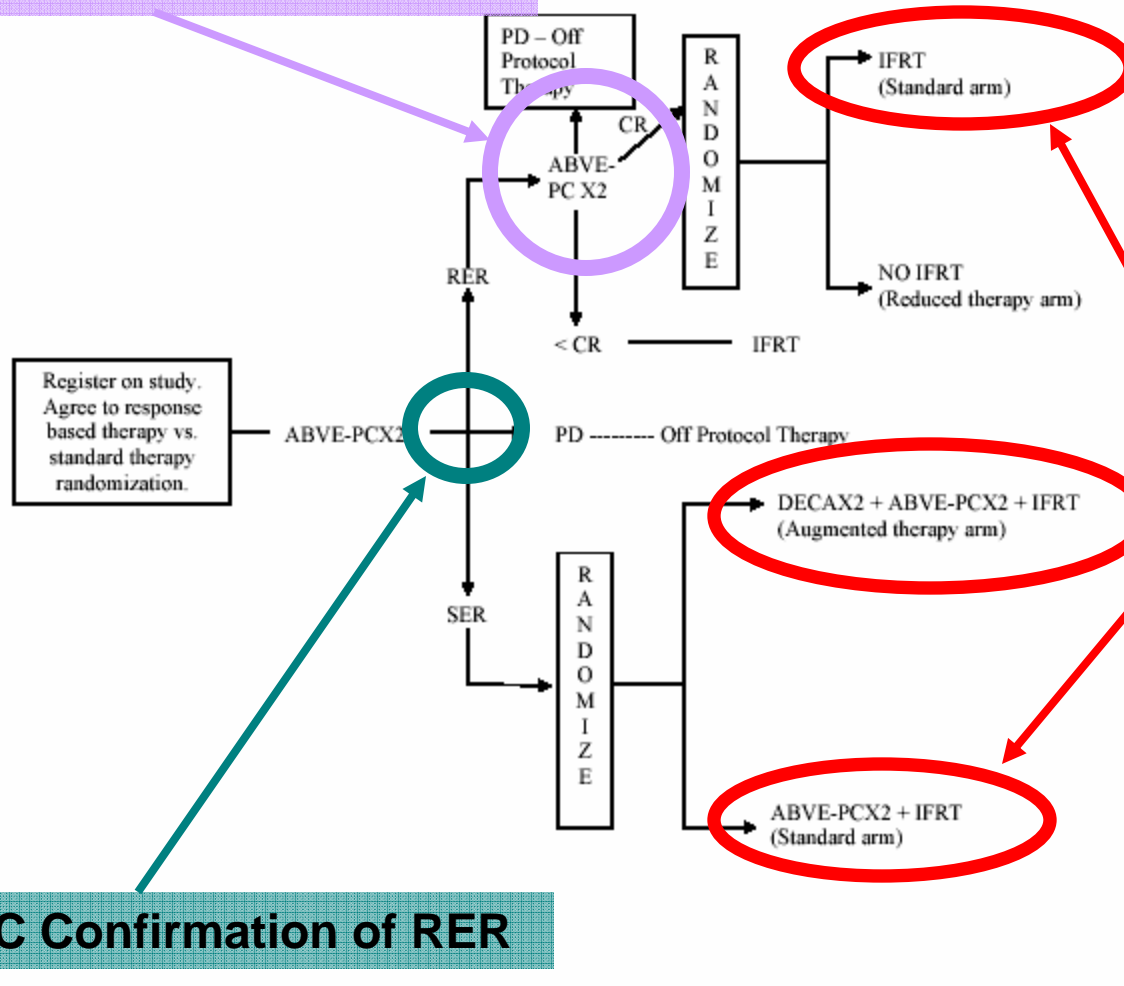

## QARC Confirmation of RER

**QARC Pre-Treatment RT Review**

# Image Based Radiation Therapy

---

---





# Digital Data

## Dicommunicator Network V2.0.6q

[Browse PACS](#)

[Manage Coop Group Data](#)

[Import Images with Email](#)

[Version](#)

[Help](#)

[Return](#)

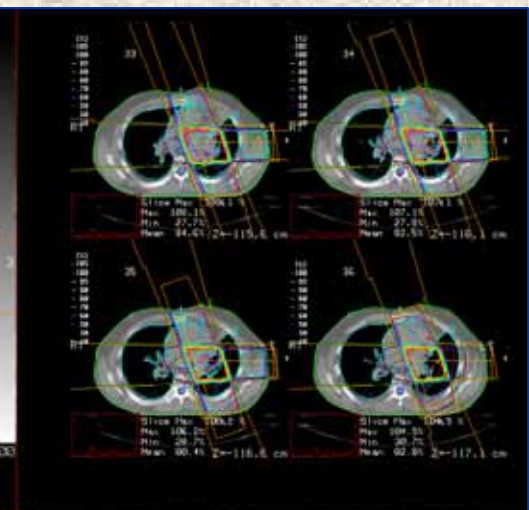
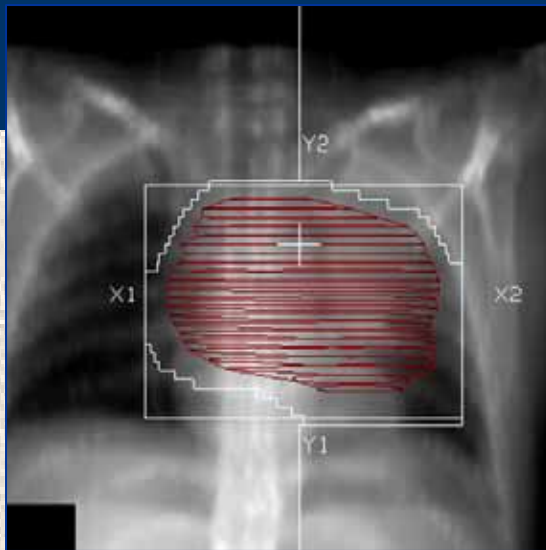
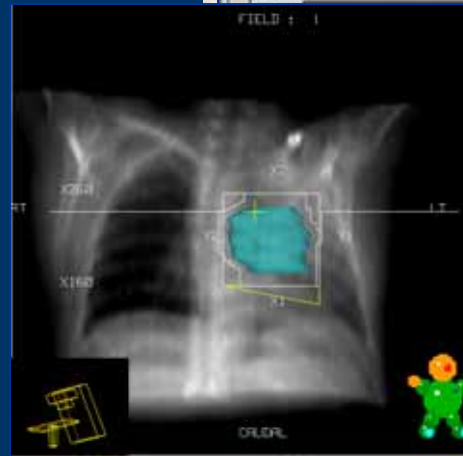
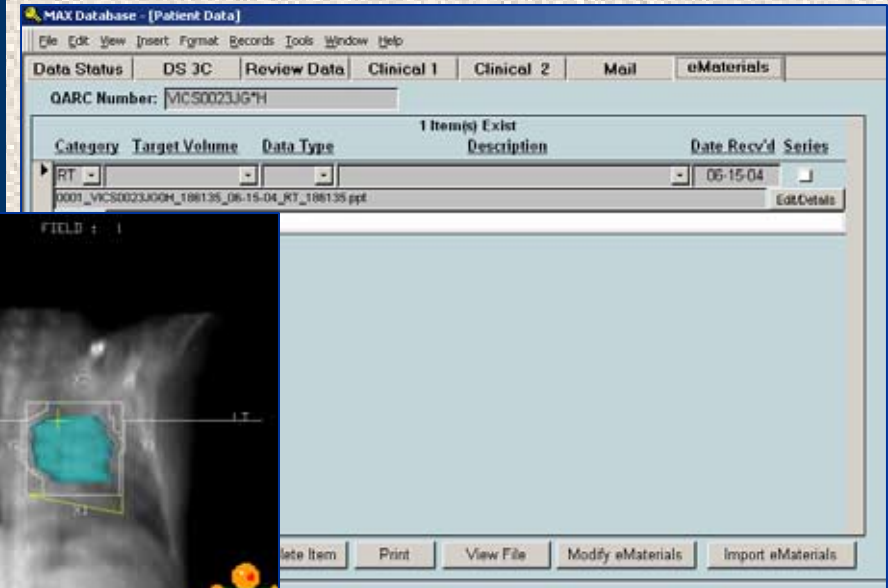

hardcopy

electronic

**Dosimetry  
Review**

Treatment records

Screen captures  
(jpegs,  
bitmaps etc.)

Isodoses  
DVHs

Printed DRRs &  
portal images

3D Dose Plan  
DICOM RT / RTOG format  
ATC (ITC) Remote  
Review Tools at QARC  
Eclipse  
CERR (QARC modified)



# Screen Captures

- **Imaging Import Wizard** – Transfers RT image data received as jpegs, bitmaps, etc. into PowerPoint files. PowerPoint file linked to patient record in database.

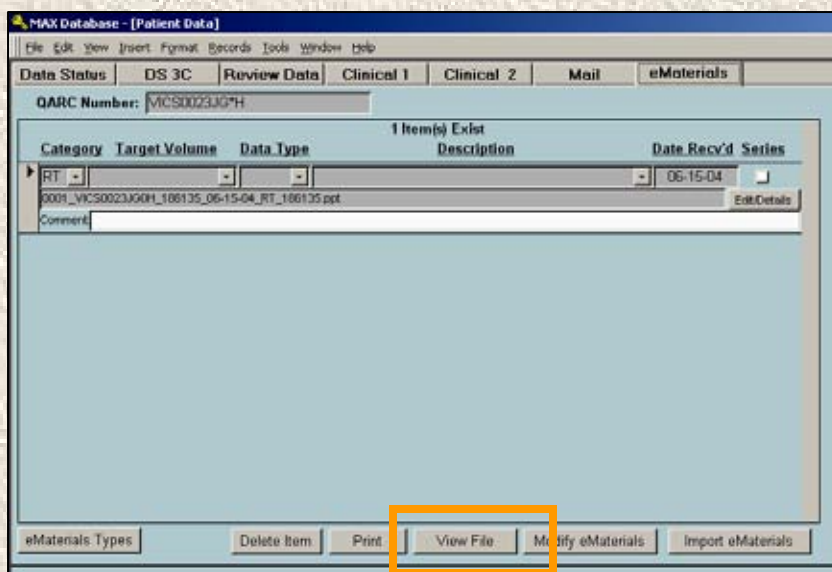
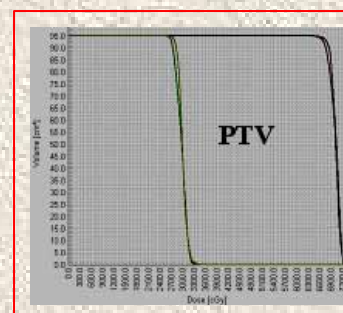
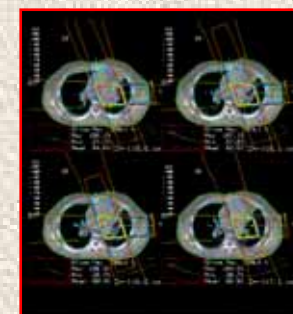
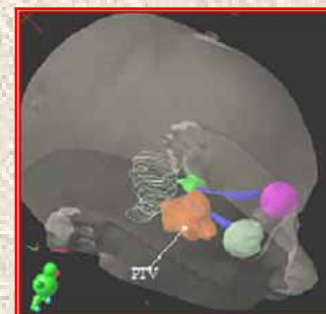

**View File**

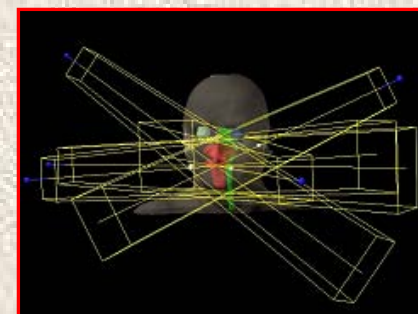

# Pre/ On Treatment Review

---

---

- **Interventional review within 24 hours**
- **WebEx when indicated**



# QARC Digital Image Management System

MAX Database - [frmPgDicomCommunicatorViewer : Form]

File Edit View Insert Format Records Tools Window Help

Type a question for help

Image Activity Attributes Filter Measure

**QARC Number**  
LDSA9961AD\*W

Coop Group: COG  
Protocol: A9961  
Case Number: 600813  
Study Date: 5/25/2000  
Preset: Unspecified  
Format: 1:1  
Interpolation: Original

**Active Tool**

Scroll  Win/Lev  
 Select  Zoom  
 Flip/Rotate  Measure

**Series Navigation**

Series: 1/6 3-Plane Localizer  
Series: 2/6 AX T1 W GAD  
Series: 3/6 AX T1 W GAD  
Series: 4/6 SAG T2 W GAD  
Series: 5/6 SAG T2 W GAD  
Series: 6/6 AX T1 W GAD

Status: Resolved  
Slice Thickness: 5.000000

P

15,113 Dicom Studies

Delete Rematch

Export Return

Record: 33 of 15113

Form View

NUM 13 July 2006

# QARC Digital Image Management System - Overview

- QARC has evolved its IT infrastructure to create an environment that can successfully manage digital DICOM imaging through...
  - developing sophisticated image transfer software (Dicommunicator)
  - evolving a comprehensive patient database into a full multi-institutional PACS
  - adapting IT environment to accommodate the different interpretations of the DICOM standard presented by various PACS vendors

# Dicommunicator

- Dicommunicator software is **installed at remote** institutions to help CRAs submit digital imaging to the Quality Assurance Review Center (QARC) in Providence, RI
  - Users can either email imaging directly to QARC, or burn to CD and submit
- Dicommunicator is also a **core component** for managing digital imaging **at QARC**
  - Used to import imaging into QARC PACS Archive and link to patient record
  - Used as a viewer for patient reviews

# Dicommunicator At QARC

- Dicommunicator development and support at QARC have become a critical component in managing digital imaging
- Software is used at QARC to import imaging into PACS archive and link to patient database
  - Imaging can be imported from any media or transmission vehicle (eg CD, DVD, email)
- Physicians can review DICOM imaging directly from the patient record in the QARC database



# Dicommunicator - Remote

- Originally developed and donated to COG by Dr. Keith White of Primary Children's Medical Center in Salt Lake City, UT
- Collaboration with QARC since 1999
- Allows the CRA to 'Pull' or 'Push' DICOM imaging from PACS to local system
- Anonymizes / Encrypts images before they are sent via email or burned to a CD
- Allows the CRA to manage which studies have been submitted and which are due

# Dicommunicator - Remote

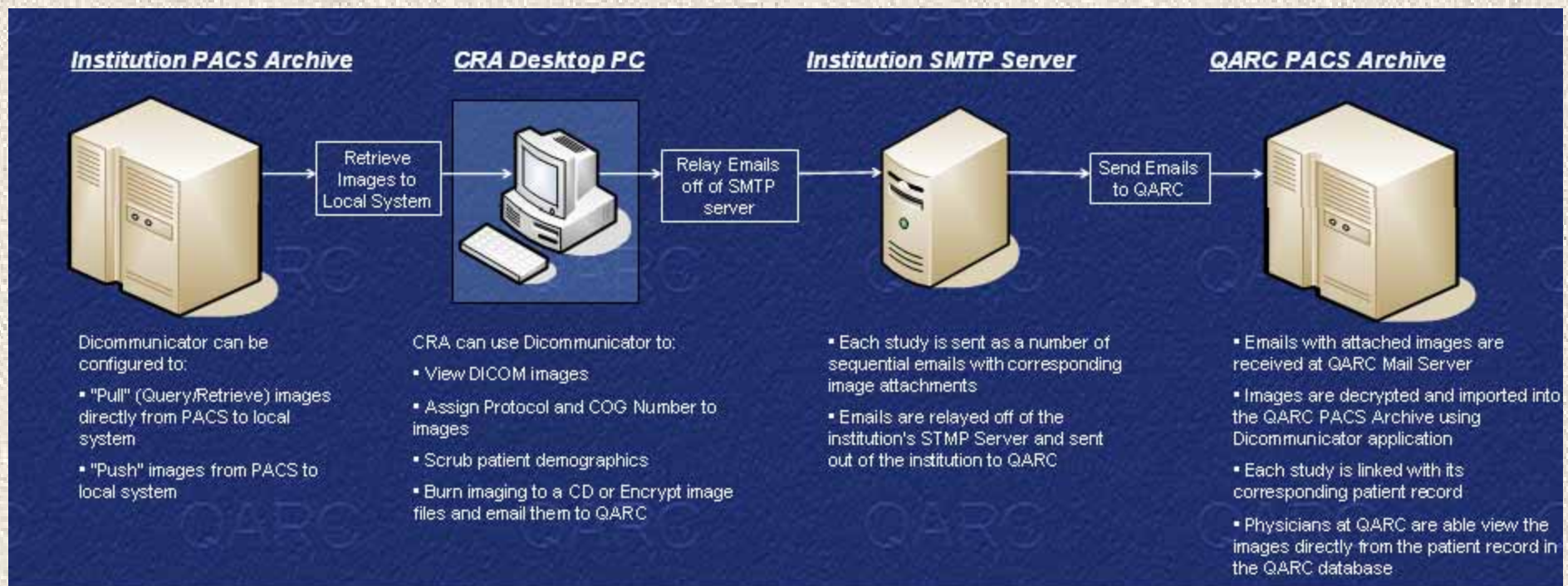

# Accomplishments

- 25 total “Fully Functional” institutions
- 7 Pending Installations
- Full Functionality with 8 major PACS manufacturers
  - Agfa, Fuji, GE, Integrad Web, Kodak, Philips, Siemens, Stentor
- Over 15,000 digital DICOM studies have been archived in the QARC PACS

# Growth of QARC PACS

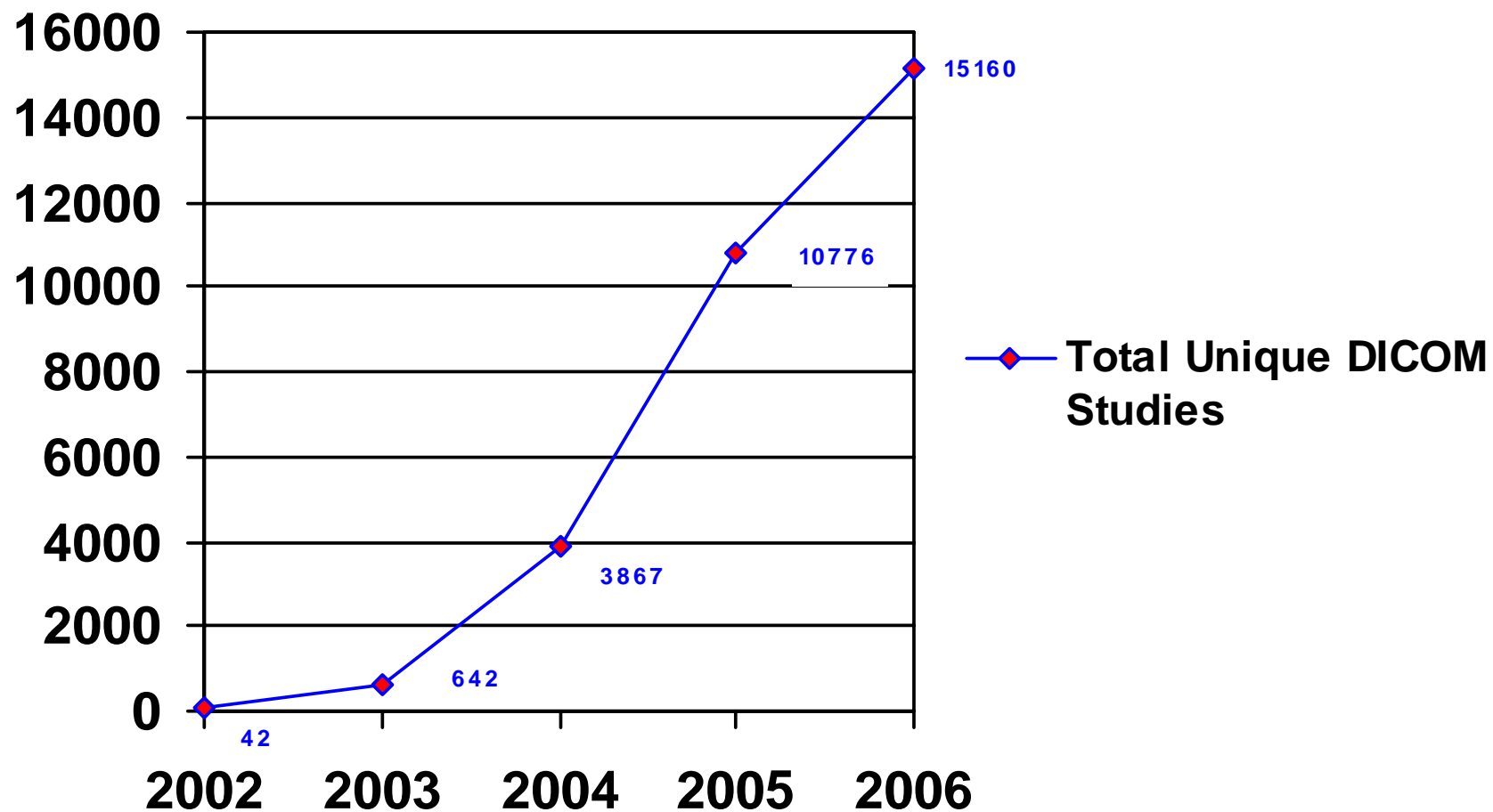

14 July 2006

# Dicommunicator .NET web viewer

- QARC CRA can post anonymized, digital DICOM imaging to a secure web server for access by reviewers off-site
- Physicians can authenticate into the imaging area of the QARC website using an assigned username and password
- Each user is given an access key to view imaging for those protocols s/he is reviewing
- Physicians use the Dicommunicator .NET web viewer to remotely review the imaging using the provided image navigation and manipulation tools
- Dicommunicator .NET web viewer has been developed by Keith S White, MD

Quality Assurance Review Center - Microsoft Internet Explorer

File Edit View Favorites Tools Help

Back Forward Stop Refresh Home Search Favorites

Address <http://www.qarc.org/> Go Links

Google Search ABC Check Look for Map AutoFill Options

# QARC

QUALITY ASSURANCE  
REVIEW CENTER

- Home
- History
- Mission
- Benchmarks
- ACOSOG
- CALGB
- COG
- ECOG
- PBTC
- SWOG
- Sanofi
- RT Forms
- Digital Data
- Industry
- Links
- Staff

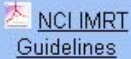

**Quality Assurance Review Center**  
272 West Exchange Street, Suite 101  
Providence, RI 02903-1025  
Phone: (401) 454-4301  
Fax: (401) 454-4683

 [NCI IMRT Guidelines](#)

Welcome to the Quality Assurance Review Center (QARC). We are a research program within the [University of Massachusetts Medical School](#) providing radiotherapy quality assurance and diagnostic imaging data management services. This is a nationally and internationally recognized program serving the [National Cancer Institute](#) (NCI) sponsored cooperative groups and the pharmaceutical industry for over three decades.

Internet

<http://www.qarc.org>

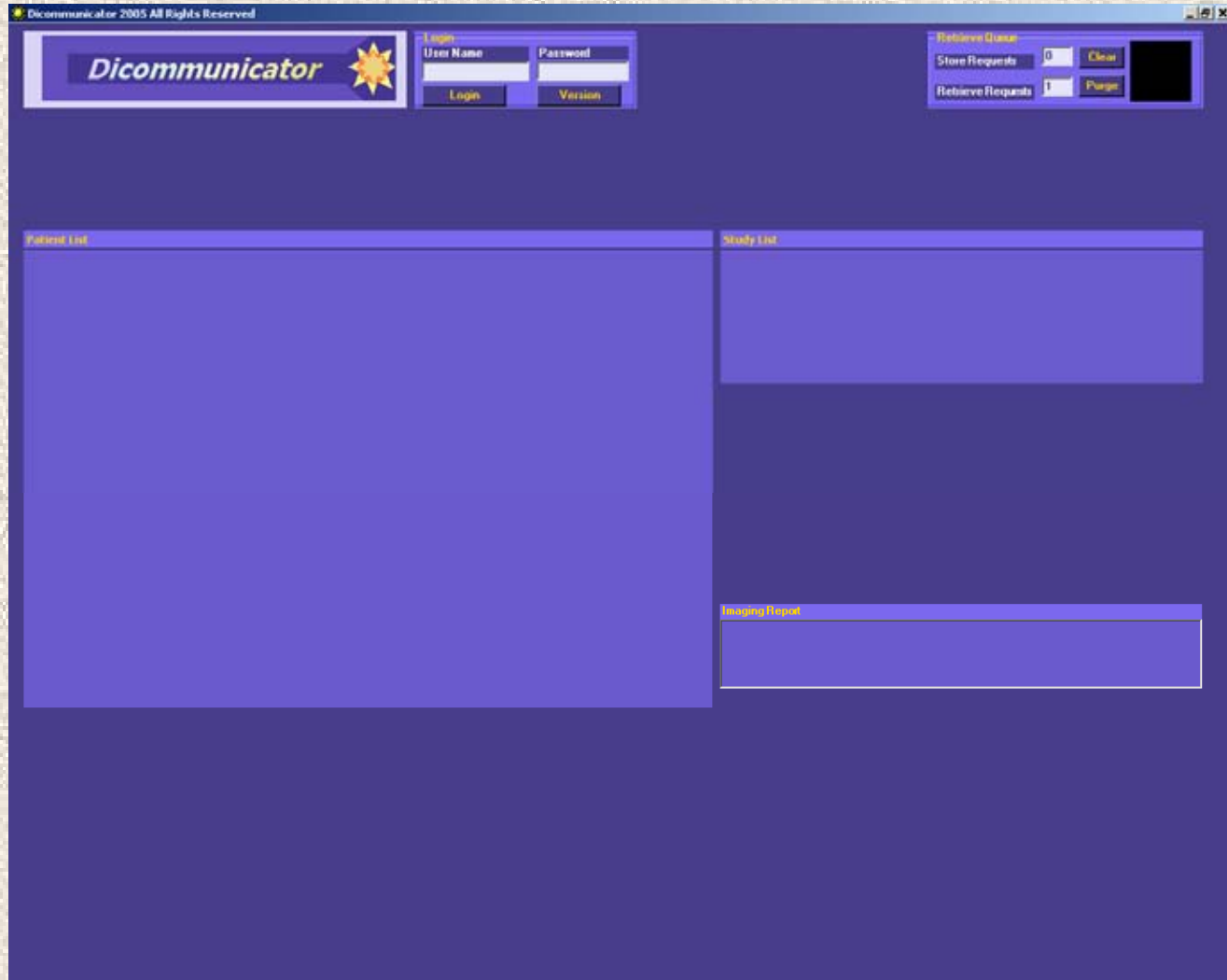

**Dicommunicator .NET Login Screen**

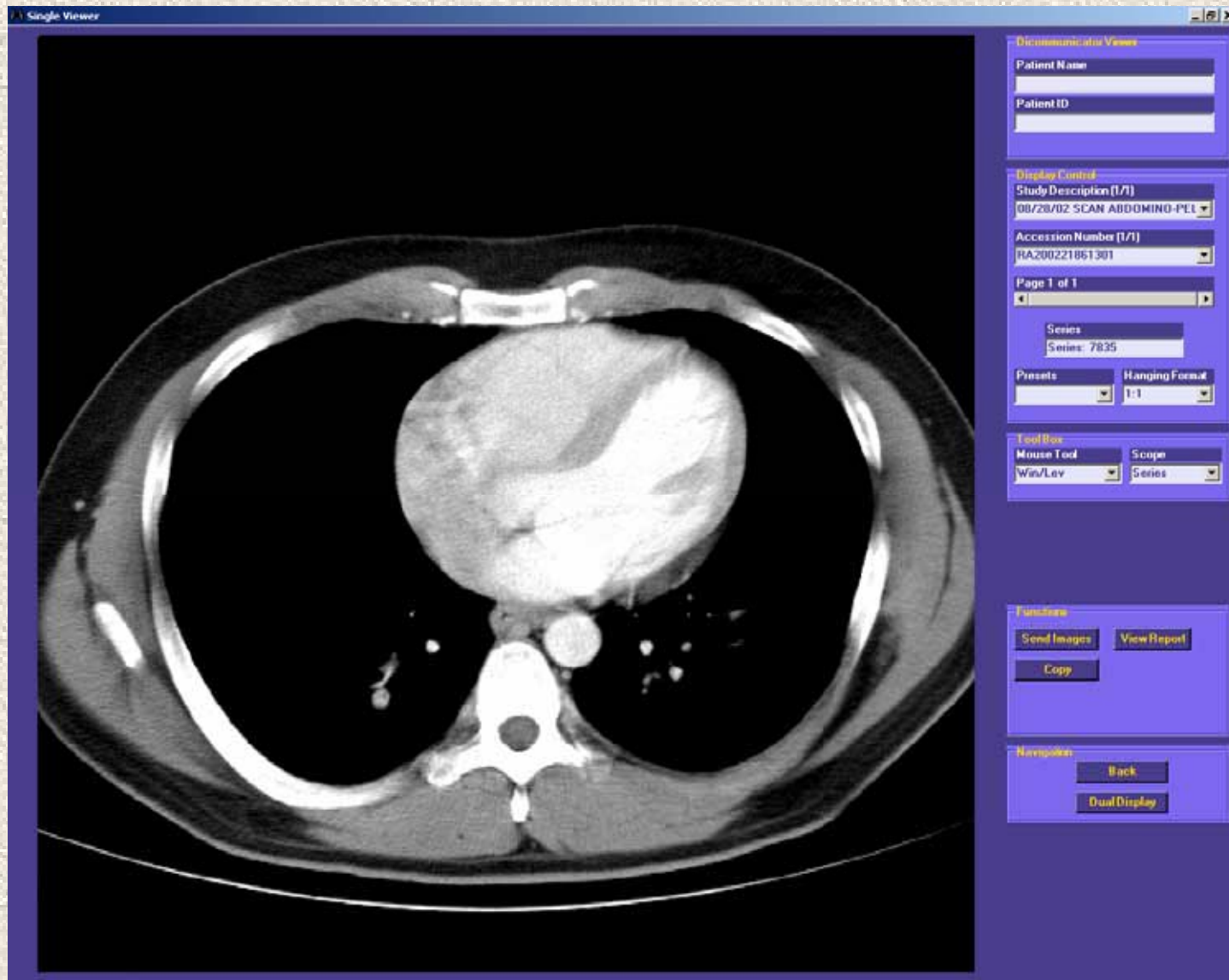

**Dicomviewer .NET Web Viewer**



# QARC Digital Image Management

## MIRC

- accepts images pushed to the site MIRC system
- anonymizes and submits images to National Cancer Imaging Archive (NCIA)
- validates and enters images into the NCIA
- authenticated users can download imaging from NCIA and display with viewer they must provide
- users must clear file archive

## Dicommunicator

- accepts files pushed from PACS and has ability to query/retrieve
- de-identifies and encrypts images before submitting electronically to QARC
- automatically purges local PC of “expired” image files
- authenticated users can download image files from QARC PACS using .NET version and display with provided viewer object

# Future Integration Strategies

- Provide a foundation for image based clinical trials
- Facilitate the development of image analysis algorithms
- Integrate multiple legacy platforms
- Must be open source
- Support caBIG standards